

REFERENCE CARD: FP428, FP528 CONSUMABLES & SUPPLIES

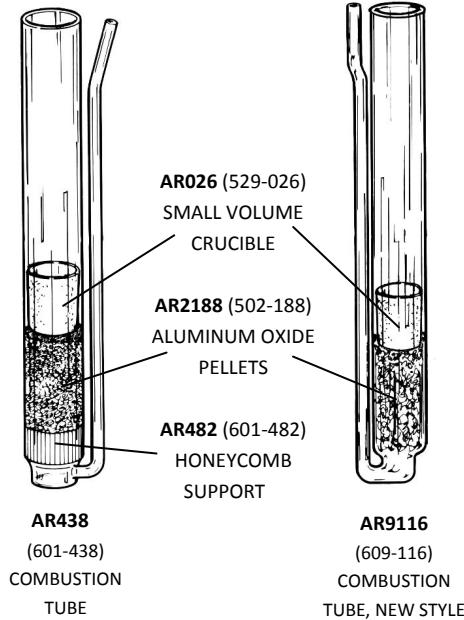

YOU CAN NOW PLACE YOUR ORDER ONLINE—VISIT US AT WWW.ALPHARESOURCES.COM
 DOWNLOAD CERTS, MSDS, OBTAIN PRICING, STOCK STATUS, FIND NEW PRODUCTS, CROSS
 REFERENCES AND MUCH MORE



GENERAL COMBUSTION SUPPLIES

- AR2188 (502-188) ALUMINUM OXIDE PELLETS 200G BOTTLE
- AR171 (501-171-HAZ) ANHYDRONE 454G BOTTLE
- AR189 (502-189) COPPER STICKS 100G AMPULE
- AR2304 (502-304) COPPER STICKS 100G BOTTLE
- AR2304-250 (502-304-500) COPPER STICKS RESEALABLE 500G BOTTLE
- AR621 (502-621) COPPER TURNINGS 200G BOTTLE
- AR615 (501-609) FURNACE REAGENT 100B BOTTLE
- AR081 (501-081) GLASS WOOL 454G BOX
- AR265 (763-265) GLASS WOOL 227G PACKAGE
- AR077 (501-077) IRON CHIP 2LB BOTTLE
- AR2174 (502-174-HAZ) ALPHASOLVE 500G BOTTLE
- AR2359 (502-359) MAGNESIUM OXIDE BEADS 200G BOTTLE
- AR049 (502-049) N-CATALYST 50G BOTTLE
- AR8379 (608-379) QUARTZ WOOL STRIPS 10/PK

AR7605
(617-605)
LARGE VOLUME
CRUCIBLE, LIQUIDS
PACKAGE OF 10

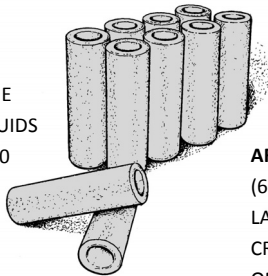

AR4961
(614-961-110)
LARGE VOLUME
CRUCIBLE, PACKAGE
OF 10

QUARTZ AND GLASSWARE

- AR441 (601-441) QUARTZ LANCE TUBE
- AR601 (775-601) GLASS BUBBLE TUBE
- AR390 (601-390) GLASS TUBE
- AR437 (601-437) REDUCTION TUBE
- AR438 (601-438) COMBUSTION TUBE FP-428
- AR9116 (609-116) NEW STYLE COMBUSTION TUBE FP-428
- AR6108 (616-108) COMBUSTION TUBE FP-528

AR4962 (614-962)
LANCE TUBE



AR6108 (616-108)
COMBUSTION TUBE



OPERATION ACCESSORIES

- AR1205 (502-005) PIPETTE BRUSH
- AR981 (601-981) WIRE BRUSH
- AR1652 (616-152) CRUCIBLE EXTRACTION TUBE
- AR5306 (775-306) SECONDARY FILTER
- AR473 (502-023) REAGENT TUBE FUNNEL
- AR6504 (616-504) PARTICLE FILTER
- AR241 (501-241) VACUUM GREASE

SAMPLE CONTAINMENT

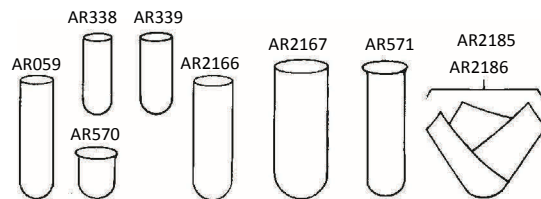

ALPHA #	LECO® #	METAL	TYPE	DIAM	HEIGHT	WEIGHT	UNIT
AR059	(501-059)	SN	CAPSULE	5.0MM	18.0MM	160MG	100
AR570	(502-008)	SN	PLUG	6.0MM	6.0MM	93MG	150
AR571	(501-571)	CU	CAPSULE	5.9MM	18MM	280MG	100
AR2166	(502-040)	SN	CAPSULE	6.0MM	18.0MM	290MG	100
AR2167	(502-167)	SN	CAPSULE	8.0MM	21.0MM	480MG	100
AR2185			PAPER	30.0MM	17.0MM	130MG	100
AR2186	(502-186)	SN	CUP	30.0MM	17.0MM	125MG	100
AR338	(502-338)		ALPHAGEL	7.0MM	17.5MM	60MG	400
AR339	(502-382)		ALPHAGEL	8.0MM	17.5MM	70MG	400

ALPHA RESOURCES INC
 PO 199, 3090 JOHNSON RD
 STEVENSVILLE, MI. 49127

PHONE: 800-833-3083
 FAX: 269-465-3629
 EMAIL: SALES@ALPHARESOURCES.COM

WWW.ALPHARESOURCES.COM

REFERENCE CARD: FP428, FP528 CONSUMABLES & SUPPLIES



YOU CAN NOW PLACE YOUR ORDER ONLINE—VISIT US AT WWW.ALPHARESOURCES.COM
DOWNLOAD CERTS, MSDS, OBTAIN PRICING, STOCK STATUS, FIND NEW PRODUCTS, CROSS
REFERENCES AND MUCH MORE

ALPHA#	LECO#	DESCRIPTION	%C	%H	%N	%O	%S
AR2092	502-092	EDTA	41.09	5.52	9.59		
AR2016	501-561	SOY BEAN			7.55		0.38
AR2017	501-272	CORN GLUTEN	45.27	5.98	10.38		0.85
AR2018	502-237	ALFALFA	42.96	5.54	3.78		0.3
AR2019	502-274	WHEAT FLOUR	38.86	5.45	1.81		0.13
AR2020	502-275	RYE	39.50	5.50	1.75		0.13
AR2025	502-563	CORN MEAL	39.60	5.55	1.65		0.14
AR2026	502-276	OAT MEAL	41.59	5.85	1.90		0.16
AR2027	502-277	BARLEY FLOUR	41.27	5.66	1.72		.13
AR2028	502-278	RICE FLOUR	40.90	5.75	1.38		0.12
AR2021	501-046	SUCROSE	42.12	6.50		0.20	
AR1053		ACETANILIDE	71.09	6.71	10.36	11.84	
AEB2036		SULFAMETHAZINE	51.78	5.07	20.12	11.49	11.52
AEB2035		CYSTINE	29.99	5.03	11.66	26.63	26.69
AEB2030		CAFFEINE	49.48	5.19	28.85	16.48	
AR4025		SOIL STANDARD			0.5		
AR4026		SOIL STANDARD			1.0		
AR4027		SOIL STANDARD			1.5		
AR4028		SOIL STANDARD			2.0		

ACCLASS
CERTIFICATE OF ACCREDITATION

ANSI-ASQ National Accreditation Board/ACCLASS
500 Montgomery Street, Suite 625, Alexandria, VA 22314, 877-344-3044

This is to certify that

Alpha Resources, Inc.
3090 Johnson Road
Stevensville, MI 49127

has been assessed by ACCLASS
and meets the requirements of international standard

ISO/IEC 17025:2005

while demonstrating technical competence in the field(s) of

CALIBRATION

Refer to the accompanying Scope(s) of Accreditation for information regarding the types of calibrations to which this accreditation applies.

AT-1200
Certificate Number
Kevin Greenway
ACCLASS Approval

Certificate Valid 12/09/2011 to 04/2014
Version No. 004 Issued: 02/16/2012



This laboratory is accredited in accordance with the recognized International Standard ISO/IEC 17025:2005. This accreditation demonstrates technical competence for a defined scope and the operation of a laboratory quality management system (refer to joint ISO/IEC 17025:2005 Communication dated January 2009).

ORINGS

- AR442 (601-442) ORING
- AR831 (780-831) ORING
- AR3913 (773-913) ORING
- AR422 (589-551) ORING
- AR2910 (772-910) ORING
- AR738 (772-738) ORING
- AR5976 (765-976) ORING
- AR520 (772-520) ORING
- AR269 (772-269) ORING
- AR781 (778-120) GASKET
- AR8116 (778-116) ORING
- AR3379 (763-379) ORING

TWEEZERS AND SPATULAS



AR1617 STRONG TIP, GENERAL PURPOSE TWEEZERS. LENGTH 5"



AR1618 CURVED POINT LENGTH 4.5"



AR1619 STRAIGHT TIP, FLAT INSIDE STRONG GRIP OF SMALL



AR1616



AR1615



AR1614 (501-614)

ALPHA RESOURCES INC
PO 199, 3090 JOHNSON RD
STEVENSVILLE, MI. 49127

PHONE: 800-833-3083
FAX: 269-465-3629
EMAIL: SALES@ALPHARESOURCES.COM

WWW.ALPHARESOURCES.COM